

Commissioning Instructions
DUOSTART 1.5 ... 22

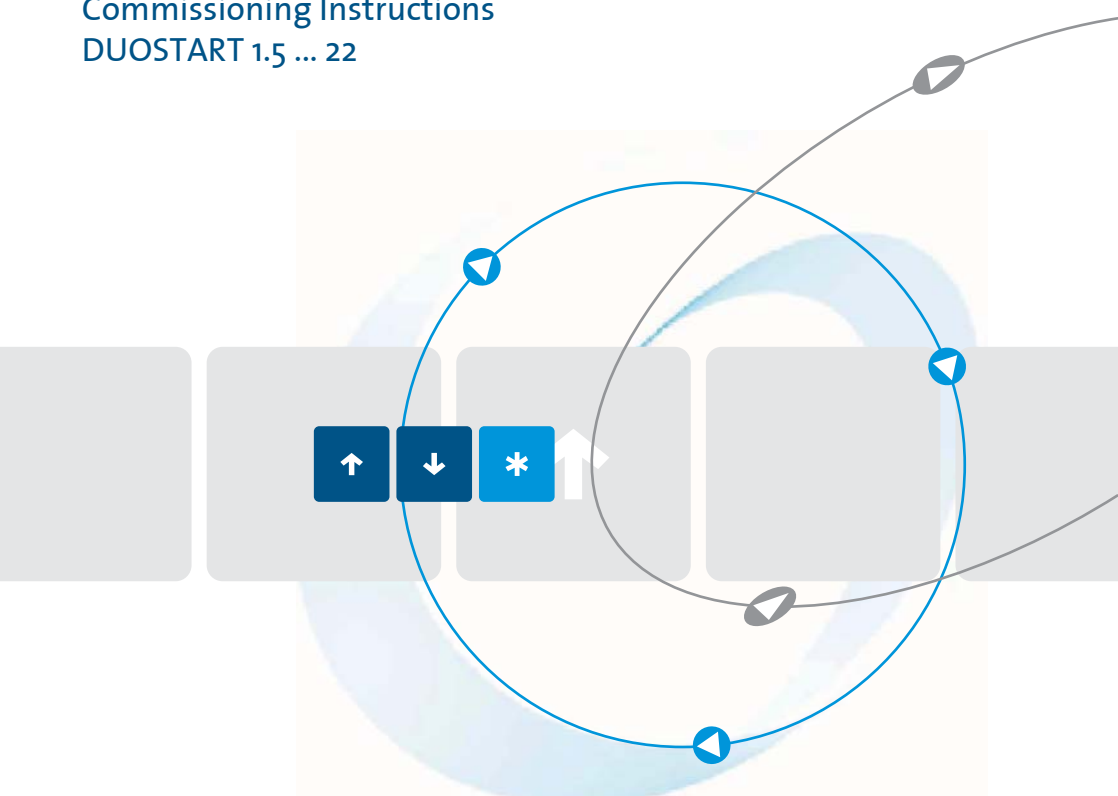

as per 05/09 11500.10001

Table of Contents	Page
1. Safety notes	3
2. Declaration of conformity	3
3. Functional principle	4
3.1 Block diagram	4
4. Installation	5
5. Control setting	5/6
6. Connecting the power unit	7
7. Connecting the control unit	7
8. Operational indications	7
9. Parameter adjustments	8
10. Commissioning	8
10.1 Adjusting soft start	8
10.2 Adjusting soft stop	8
11. Technical data	9
11.1 Electrical data	9
11.2 Ambient conditions	9
11.3 Options	9
12. Installation guidelines	10
12.1 Connection diagram	10
12.2 Typical connections	11
12.3 Dimensional drawing	12

These commissioning instructions were made with great care. Nevertheless, the PETER electronic GmbH & Co.KG does not assume liability for damage resulting from mistakes possibly contained in this manual. Technical changes that serve to improve the product are subject to change without notice.

1. Safety notes

The described devices are electrical equipment for the application in industrial electrical power installations. An impermissible removal of the covers during operation can cause serious damage to your health, since these devices contain live parts with high voltages.

Adjustment work may only be performed by trained staff observing the safety regulations. Assembly and mounting work may only be carried out with the equipment de-energized.

Make sure that all the drive components are properly earthed.

Read these commissioning instructions carefully before putting the soft starter into operation.

Besides, the user must ensure that the devices and associated components are fitted and connected in accordance with the applicable local, legal and technical regulations. The VDE-regulations VDE 0100, VDE 0110, VDE 0160 and VDE 0113, plus the appropriate regulations of the TÜV (Technical Inspectorate) and the employers' liability insurance associations apply in Germany.

The user must make sure that the drive assumes a safe operating state following a device failure, in the event of maloperation, or if the control unit has failed etc..

Even if the motor is at rest, it is **not** physically separated from the mains.

2. Declaration of conformity

In industrial linguistic usage the drive controllers of the type DUOSTART are called "devices", however, in the sense of the "device-safety-law", the "EMC-law" or the "EC-guideline for machinery" they are not devices or machines ready for use or connection but they are components. It is only possible to define their final function, when these components are integrated into the design and construction of the user.

To be able to use the devices to their intended purpose, it requires power supply networks according to DIN EN 50160 (IEC38) .

The user takes the responsibility to ensure that the user's design and construction comply with the applicable legal provisions.

The commissioning is strictly forbidden as long as the conformity of the final product with the guideline 2006/42/EC (machinery guideline) is not proved.

The devices of the DUOSTART-series are electrical equipment that is used in industrial electrical power installations. They are designed for the application in machines, in order to reduce the starting torque or the inrush peaks and the soft stop torque of drives with three-phase motors. With due regard to the installation guidelines they meet the following requirements:

Emitted interference:	Continuous duty	EN 50081-1
	Ramp-up,ramp-down	EN 60947-4-2, IEC 947-4-2
Immunity to interference:	EN 50082-2	1995

CE

Dr. Thomas Stiller
Managing Director



3. Functional principle

In the case of the soft starters of the DUOSTART-type the motor voltage is changed in two phases (1L1/5L3) by means of a generalized phase control and power semiconductors. Starting from an adjustable start trigger angle the trigger angle is continuously reduced. During the adjusted ramp-up time the motor torque increases according to a ramp function until the maximum value is reached. When the acceleration time is over, the power semiconductors are bypassed by integrated relays and the motor is directly supplied from the mains.

After the start/stop-contact has opened, the trigger angle is continuously increased via a ramp function, and thus, the motor is softly slowing down.

The acceleration time, the starting torque and the deceleration time can be separately adjusted with a potentiometer each.

The acceleration or deceleration is effected by closing or opening the contact on the terminals X1/X2.

The power unit supplies the voltage for the control electronics. Upon request, the power supply can also be implemented by means of an external power supply unit (24V min 100mA DC or AC).

3.1 Block diagram

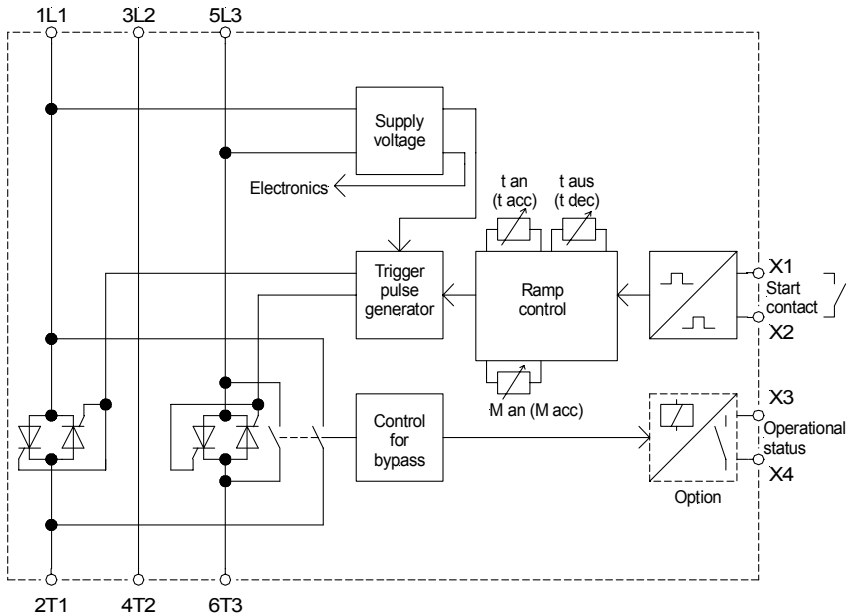

4. Installation

The device has to be fitted on a vertical mounting surface, with the motor terminals facing downwards. Make sure that no additional heat sources, such as resistors etc. are placed underneath the device.

Maintain a clearance of at least 40mm between the cable duct and the device, in order to avoid heat concentrations. The devices can be mounted directly side by side.

The devices are to be snap-mounted onto a 35mm top-hat rail according to DIN EN 50022.

5. Control setting

The DUOSTART devices will be controlled alternative in two control modes.

1. Start/Stop through contact or switching transistor (standard)
2. Start/Stop through control voltage 10 ... 42VDC

The devices DUOSTART 1.5 ... 5.5 can be switched over by re-arranging a jumper. For this purpose the central board has to be snapped out of the upper part of the housing. Between the left-hand and the central potentiometer there is the 3-pole jumper-plug „BR1“. The jumper is factory-plugged to „Contact“ position (front plug-in position). If you plug the jumper into „Voltage“ position, the control with 10 ... 42VDC is possible.

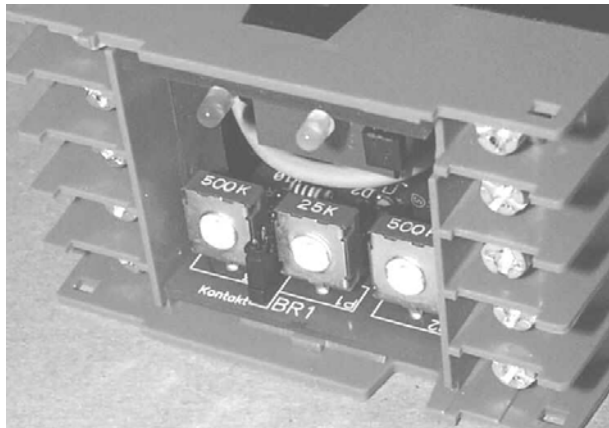

For the DUOSTART 7.5 ... 22 the transparent window must be removed. Now it is possible to change the jumper BR1 to position "S" ("K" is factory setting) and the control mode is set for a control by means of 10 ... 42VDC.

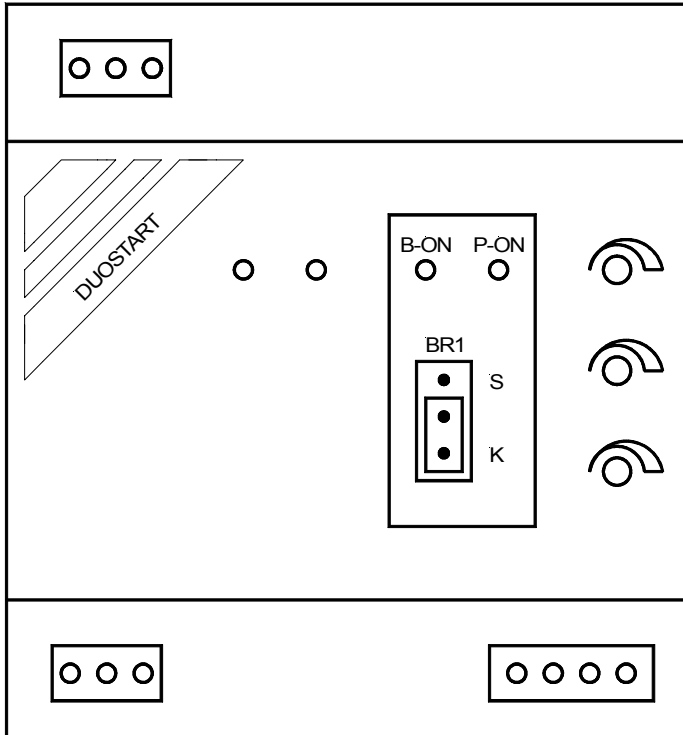

6. Connecting the power unit (see also connection diagram)

Terminal 1L1:	Mains voltage L1
Terminal 3L2:	Mains voltage L2
Terminal 5L3:	Mains voltage L3
Terminal 2T1:	Motor terminal U
Terminal 4T2:	Motor terminal V
Terminal 6T3:	Motor terminal W

7. Connecting the control unit

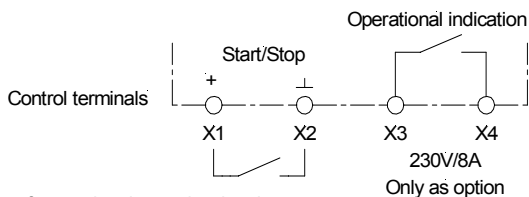

Contact for acceleration or deceleration
 Contact loading
 12VDC/15mA
 or
 control voltage 10...42VDC

If a contact is closed across terminals X1 and X2, the motor starts with the adjusted ramp-up time. When the contact is open, the motor runs down with the adjusted ramp-down time. The motor, however, is not physically separated from the mains.

As option, an output with a relay contact indicating the operating state of the device is obtainable. Upon request, the operating state indications "top of ramp" or "device in operation" can be delivered.

Optionally, the control input can also be set for a control by means of d.c. voltage (see point 5).

If only soft starting is required, the DUOSTART can also be controlled via the main contactor. For this purpose the terminals X1 and X2 have to be jumpered.

8. Operational indications

2 LEDs indicating the following operating states are located on the control board.

LED	Operating state
green	device connected to mains voltage
yellow	top of ramp

As an option, a signalling contact on the terminals X3 and X4 is obtainable (DUOSTART ... M), which is closed from the beginning of the soft start to the end of the soft stop.

9. Parameter adjustments

3 potentiometers that enable the following adjustments are located on the front side.

Parameter	Poti	Adjustment range
Breakaway torque	M_{acc}	0...80% Poti turned to right stop = maximum torque
Acceleration time	t_{acc}	Acceleration time adjustable from 0.5...12sec Poti turned to right stop = longest acceleration time
Deceleration time	t_{dec}	Deceleration time adjustable from 0.5...12sec Poti turned to right stop = longest deceleration time

10. Commissioning



Attention

If the ramp-up time is adjusted too short, the internal bypass contact closes before the motor has reached its nominal speed. This can cause damage to the bypass contactor or the bypass relay.

10.1 Adjusting soft start

Potentiometer M_{acc} (breakaway torque)	= left stop
Potentiometer t_{acc} (acceleration time)	= centre position
Potentiometer t_{dec} (deceleration time)	= left stop

Switch on the DUOSTART and select soft start.

Turn the potentiometer M_{acc} clockwise so far that the motor starts up immediately. Avoid unnecessary humming when the motor is at rest.

Adjust the potentiometer t_{acc} until the required acceleration time or acceleration characteristic is reached.

Turn potentiometer t_{acc} counter-clockwise as far as possible!

While ensuring good acceleration characteristics, this results in short times until the bypass contactor is energized, and consequently the power semiconductors and the motor are less heated. This is particularly important in the case of high loading and many switching cycles.

10.2 Adjusting soft stop

Potentiometer t_{dec} = centre position

In order to enable soft stop, the DUOSTART, during the deceleration phase, must remain switched on with the three-phase mains.

In the case of these devices the soft stop torque is fixed to 70%.

Now, adjust potentiometer t_{dec} until the required deceleration time or deceleration characteristic is reached.

Attention: Even if the motor is at rest, it is not physically separated from the mains.

It must be ensured that the specified switching cycle is not exceeded!

11. Technical data

11.1 Electrical data

Type designation	DUOSTART					
	1.5	3	5.5	7.5	11	22
Mains voltage according to DIN EN 50160 (IEC 38)	400V ±10% 50/60Hz special voltages: 220/240V 50/60Hz 460/480V 50/60Hz					
max. Motor rating	at 230V		at 400V		at 460V	
	0.75kW	1.5kW	2.2kW	4kW	5.5kW	11kW
	1.5kW	3.0kW	5.5kW	7.5kW	11kW	22kW
	-	4.0kW	5.5kW	7.5kW	15kW	22kW
min. Motor load	40% of the device power rating					
External fuses „high-speed“	16A	25A	36A	50A	125A	160A
Device nominal current	3.5A	6.5A	12.0A	15A	25A	45A
Adjustment range of breakaway torque	0...80%					
Adjustment range of acceleration time	0.5 ... 12s (special times upon request)					
Soft stop torque	fixed setting to 70%					
Adjustment range of deceleration time	0.5 ... 12s					
Repeatability	200 ms					
max. Switching cycle (3 x I _{Nom} , 10sec)	90/h	60/h	30/h	60/h	30/h	20/h
Wire range	solid		stranded			
	2x2.5mm ²	2x2.5mm ²	2x2.5mm ²	6mm ²	6mm ²	16mm ²
	2x1.5mm ²	2x1.5mm ²	2x1.5mm ²	4mm ²	4mm ²	10mm ²

DUOSTART 1.5 is not available as 460/480V version.

10.2 Ambient conditions

Operating temperature	0° ...45°C
Storage temperature	-25° C...75° C
Protection class	IP 20
Environment	Overvoltage category III, pollution degree 2

10.3 Options

DUOSTART ... M

Potential-free output indicating the operating state

11. Installation guidelines

11.1 Connection diagram

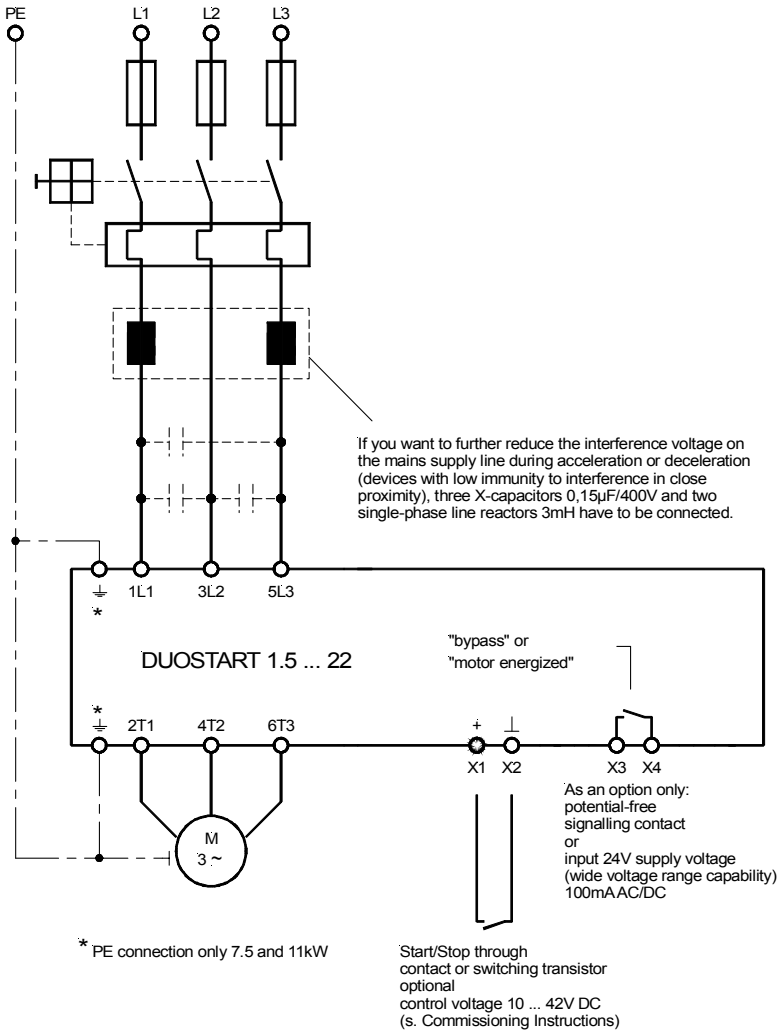

12.2 Typical Connections

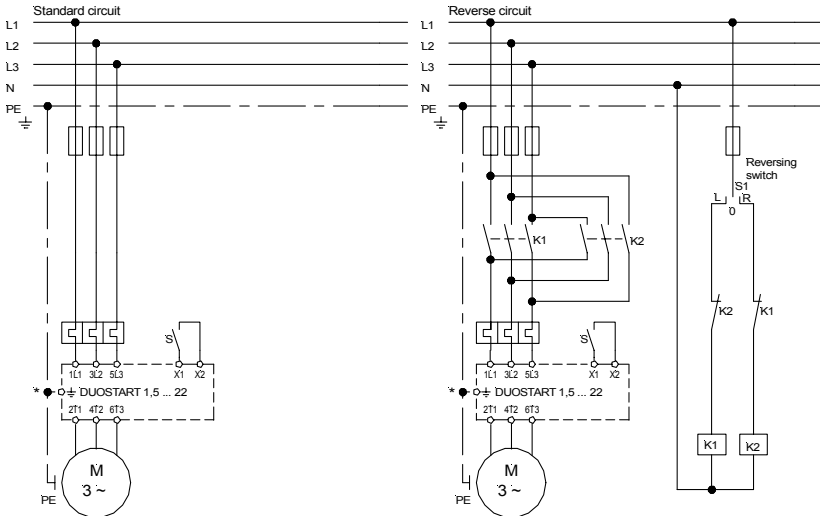

S - closed = soft start; S - open = soft stop
 * PE connection only 7.5 and 22kW

S - closed = soft start; S - open = soft stop

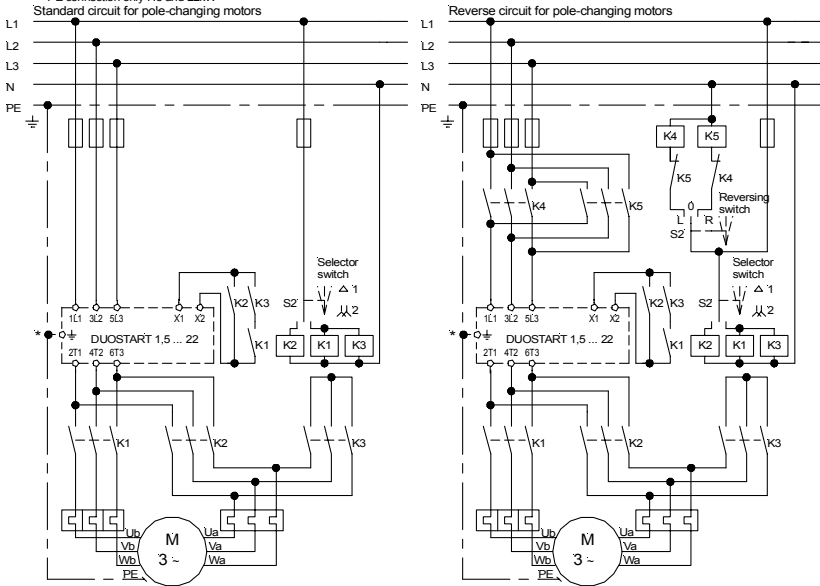

For pole-changing motors trimmer t aus to 0 (left stop)

12.3 Dimensional drawing

DUOSTART 1.5 ... 5.5

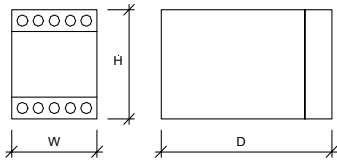

DUOSTART 7.5 / 11 / 22

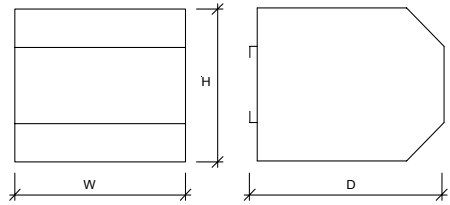

Installation dimensions	W	H	D
DUOSTART 1.5 ... 5.5	45mm	73mm	122mm
DUOSTART 7.5 / 11	90mm	105mm	105mm
DUOSTART 22	165mm	105mm	105mm

Notes:



www.peter-electronic.com

